

Cranes

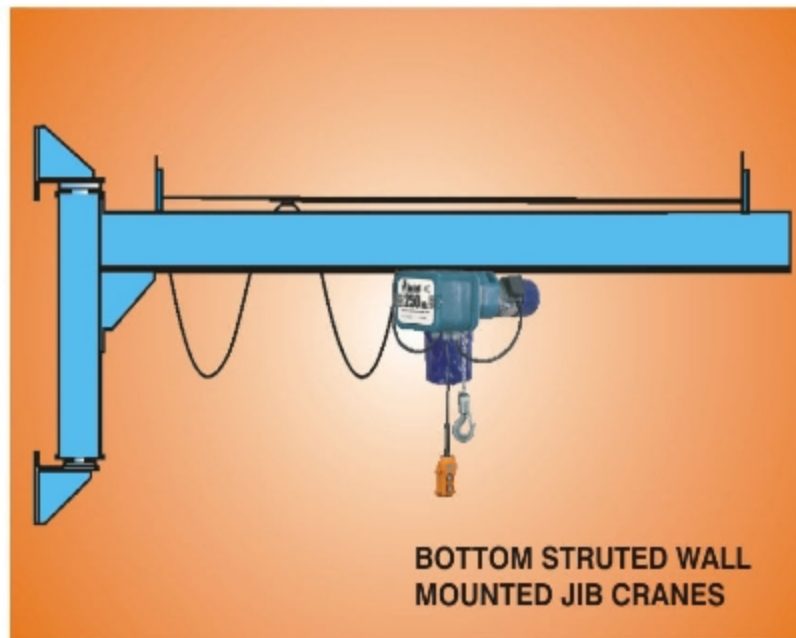
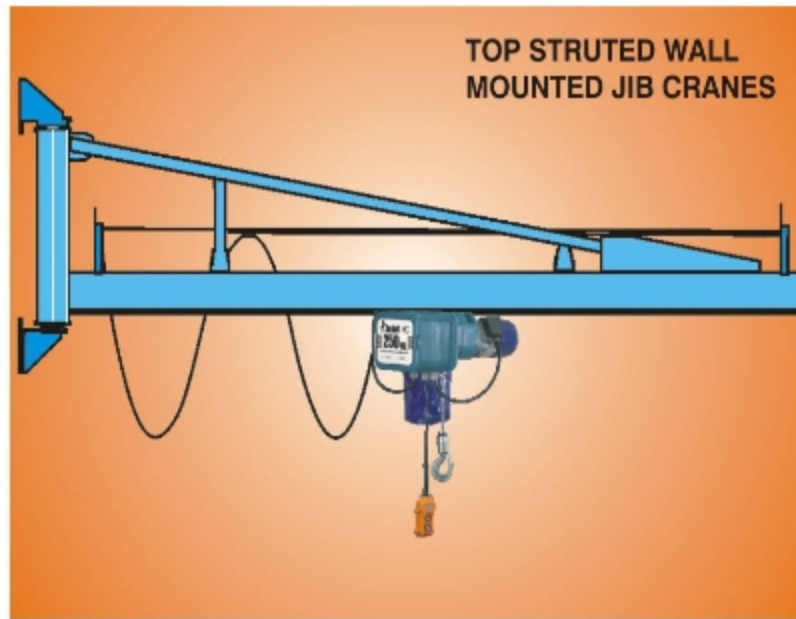
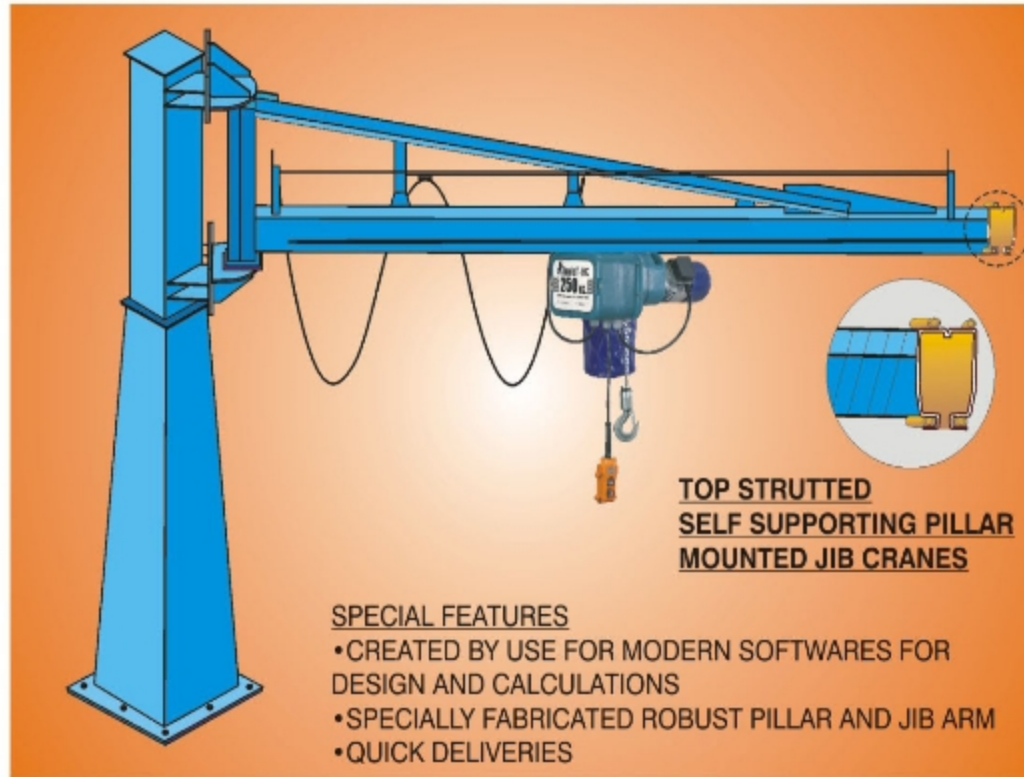

Jib crane

Jib crane consists of jib arm made from light profile section and are supported on anti friction bearing to ensure long trouble free service. The arm can swing 270°. The arm is provided with end stoppers to limit the travel of trolley for lifting equipment. And supports the trailing cable system which supplies power to lifting equipment. The braking system is provided to prevent the arm from swing at higher speeds due to inertia of load, structure.

The arm is supported on a robust pillar fabricated from steel plates.

The pillar is tapering so that the increased section at the base provides good rigidity to the structure. The pillar and arm are designed to ensure minimum deflection at loaded conditions. Jib arm of wall mounted jib cranes is supported by brackets bolted on wall, or on column of existing structure.

The jib cranes are designed to suit all the required specifications of our customers.

We provide our standard electric hoists manually operated hoists as per the requirements of our customers.

Jib cranes are available in two types in following range.

- 1) Self supported pillar mounted.
- 2) Wall mounted

Capacity : 250 Kg. to 6000 Kg.
 Jib Radius : upto 6M.
 Lift : 10 Mtrs.
 Seen : Manual / Electric



Manufactured & Marketed by :
HERCULES HOISTS LTD.

CTS No. 43/5, Village Dhamni, Taluka Khalapur,
 Khopoli, Dist. Raigad, Maharashtra-410 202. India
 Tel. : + 91 (0) 2192-274036/274087/274135
 Fax : + 91 (0) 2192-274325
 E-mail : enquire@indef.com
 Website : http://www.indef.com

Dealers name & address

