

HW - 4 HIGH LIFT WIRE ROPE HOISTS

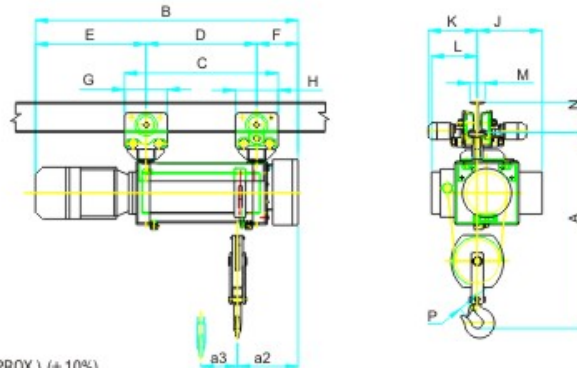

SPECIFICATION & DIMENSIONS (APPROX.) (± 10%)

TYPE		HW4 HIGH LIFT										
		H1	H2	H3	H4	H5	H1	H2	H3	H4	H5	
DRUM LENGTH.	MM	1450	1700	1950	2200	2450	1850	2150	2450	2750	3050	
SWL CLASS - II	TONNES	12					20					
SWL CLASS - IV	TONNES	10					16					
LIFT	M	25	30	35	40	45	25	30	35	40	45	
NO. OF FALLS		<p>4 FALLS</p>										
WIRE ROPE DIA.	mm	13					18					
HOISTING SPEED	M/MIN.	3.8										
HOISTING MOTOR KW.	KW	15										
TRAVELLING SPEED	M/MIN.	17										
TRAVELLING MOTOR KW.	KW	0.75 KW (2 NOS.)										
DIMN. A (HEAD ROOM)	mm	1800										
DIMN. ((B)) Note-5	((mm))	2126	2376	2626	2876	3126	2526	2826	3126	3426	3726	
DIMN. C	mm	1770	2020	2270	2520	2770	2294	2594	2894	3194	3494	
DIMN. D	mm	1414	1664	1914	2164	2414	1814	2114	2414	3014	3014	
DIMN. E	mm	Note-5 (735)					(735)					
DIMN. F	mm	356					356					
DIMN. G	mm	356					480					
DIMN. H	mm	356					480					
DIMN. J	mm	500					500					
DIMN. K	mm	410 - 460					410 - 460					
DIMN. L	mm	381					420					
DIMN. M	mm	125 - 210					150 - 210					
DIMN. N (MIN.)	mm	250					450					
DIMN. P	mm	78					95					
DIMN. a2	mm	548					652					
DIMN. a3	mm	99	155	220	317	415	91	135	185	260	335	
APPROX. WEIGHT	HOIST	Kg	480	504	510	550	596	530	550	570	590	696
	TROLLEY	Kg	140	140	140	140	140	180	180	180	180	180
	TOTAL	Kg	620	644	650	690	736	710	730	750	770	876

NOTES:

- 1:3 CREEP SPEED CAN BE GIVEN AT EXTRA COST & DIMENSION 'E' WILL INCREASE BY 165 MM.
- 2) TROLLEY BRAKE CAN BE SUPPLIED AT EXTRA COST AND DIMENSION 'K' WILL INCREASE BY 125 MM.
- 3) 13, 26 MPM TROLLEYS ALSO CAN BE SUPPLIED (SINGLE REDUCTION GEAR BOX)
- 4) 2, 2.8, 4, 8, 9 MPM TROLLEYS ALSO CAN BE SUPPLIED (DOUBLE REDUCTION GEAR BOX) AT EXTRA COST AND 'K' DIMENSION WILL INCREASE BY 46
- 5) SPECIFICATIONS IN (()) ARE FOR IMPORTED (COEL) MOTOR WITH AC BRAKES.
SPECIFICATIONS IN () ARE FOR LOCAL (BBL) MOTOR WITH AC BRAKES.